

SE 110.29

Torsion of bars



The illustration shows SE 110.29 in the frame SE 112.

Description

- elastic torsion of a bar under a torque
- round bar, tube, longitudinally slotted tube and square tube as test bars
- indication of the angle of twist at two random points on the bar

Torsion occurs primarily on axles and drive shafts in motor vehicles and machines. The torsion occurring in the shaft cause cross-sections of the shaft to be pushed together around the longitudinal axis. When a torque is applied to a shaft the cross-section remains flat and no warpage occurs.

In the event of minor torsion the length and radius remain unchanged. The straight lines on the outer circumference of the shaft running parallel to the axis become helixes. Non-circular cross-sections mostly result in warpage.

SE 110.29 investigates the torsion of a bar under a torque. The bar is clamped into two movable support blocks by a chuck. The torque is generated by a circular disk, a deflection roller and a weight.

The clamping length and torque can be varied. The resultant torsion is read-off at two random points on the bar by means of angle indicators.

The fundamentals of elastic torsion are illustrated by the round bar. Three other bars are provided in order to investigate special cases: two thin-walled enclosed sections (a tube and a square tube) and a longitudinally slotted tube (thin-walled open section).

All the component elements of the experiment are clearly laid-out and housed securely in a storage system. The complete experimental setup is arranged in the frame SE 112.

Learning objectives/experiments

- torsion of a bar
- shear modulus of elasticity and second polar moment of area
- angle of twist dependent on clamping length
- angle of twist dependent on torque
- influence of rigidity on torsion
 - ▶ tube
 - ▶ tube, longitudinally slotted
 - ▶ square tube
- calculation of angle of twist
- comparison of calculated and measured angle of twist

SE 110.29

Torsion of bars

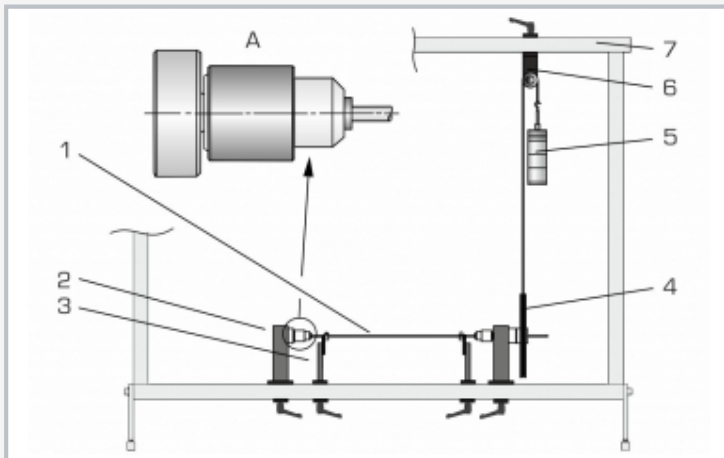

1 bar, 2 support block with clamping chuck, 3 angle indicator, 4 disk to apply moment, 5 weight, 6 deflection roller with fixture, 7 frame SE 112, A: clamping chuck

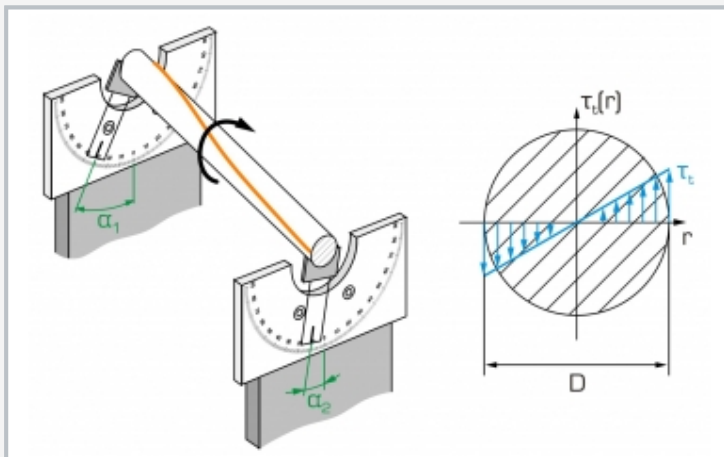

Torsion of a bar and measurement of the angles α_1 and α_2 , right: shear stresses on the circular section

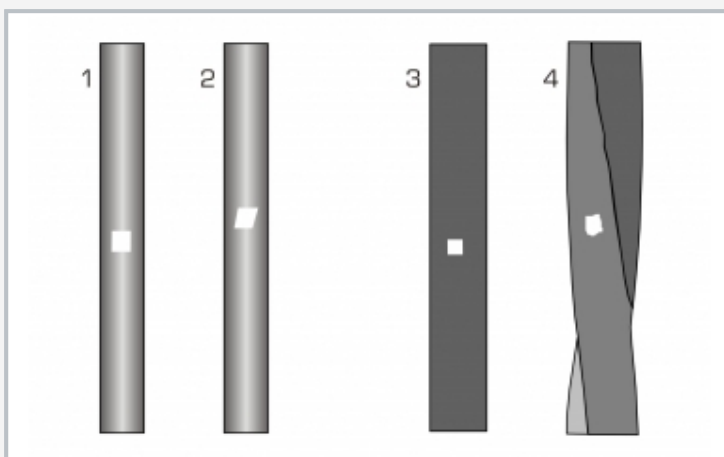

Deformation of a rectangular surface element (white): 1 round bar, not deformed, 2 round bar, twisted, 3 square tube, not deformed, 4 square tube, twisted

Specification

- [1] elastic torsion of bars
- [2] 2 movable support blocks with clamping chuck for mounting of bars, 1 fixed and 1 movable support
- [3] 2 movable angle indicators clampable to the bar
- [4] 4 bars: round bar with full cross-section, tube, longitudinally slotted tube, square tube
- [5] application of load to the bar by a mass disk, a deflection roller and weights
- [6] storage system to house the components
- [7] experimental setup in frame SE 112

Technical data

4 brass bars, $L=695\text{mm}$

- round bar, $\varnothing=6\text{mm}$
- tube, slotted tube $\varnothing=6\text{mm}$, wall thickness: 1 mm, slot width: 0,3mm
- square tube $W \times H$: 6mm, wall thickness: 1 mm

Disk to apply the load

- effective radius: 110mm

Angle indicator

- measuring range: $\pm 90^\circ$
- graduation: 1°

Weights

- 1x 1N (hanger)
- 4x 1N
- 3x 5N

$L \times W \times H$: 1170x480x178mm (storage system)

Weight: approx. 27kg (total)

Scope of delivery

- 2 support blocks with clamping chuck
- 2 angle indicators
- 4 bars
- 1 deflection roller with fixture
- 1 cable
- 1 set of weights
- 2 hexagon socket wrenches
- 1 storage system with foam inlay
- 1 set of instructional material

SE 110.29

Torsion of bars

Required accessories

022.11200 SE 112 Mounting frame