

# FL 160

## Unsymmetrical bending



### Description

- **symmetrical and unsymmetrical bending on a beam**
- **symmetrical and unsymmetrical cross-sectional profiles: I, L and U**
- **combined bending and torsion loading by way of eccentric force application**

Symmetrical bending of a beam – also known as uniaxial bending – occurs when the load plane coincides with one of the main axes of the beam cross-section. The beam then deflects in the direction of the load and can be described by elastic lines.

In unsymmetrical bending of a beam – also known as complex or biaxial bending – the main axes of the cross-section do not coincide with the direction of loading. To prevent torsion, the line of application of the load must pass through the shear centre. If it does not, the beam undergoes combined bending and torsion loading.

FL 160 is used to perform experiments relating to symmetrical and unsymmetrical bending and to combined bending and torsion loading. The beam under investigation is clamped into place on one end and loaded down at the free end. Two dial gauges record the horizontal and vertical deformation of the beam.

The unit includes three beams with different cross-sectional profiles: I, L and U. The beam can be clamped with freedom to rotate in any direction. This enables investigation of loading along the main axis or of the general load case. An angle scale at the clamping point indicates the angular position of the beam. It is possible to adjust the load application point eccentrically, so that purely unsymmetrical bending or combined bending and torsion loading is investigated.

The various elements of the experiment are clearly laid-out and housed securely in a storage system.

### Learning objectives/experiments

- product moment of inertia ( $I_{yz}$ ) and axial second moment of area ( $I_y, I_z$ )
- Bernoulli hypothesis
- symmetrical bending on a beam (uniaxial)
  - ▶ with I-profile
  - ▶ with L-profile
  - ▶ with U-profile
- unsymmetrical bending (complex) on a beam with an L-profile
  - ▶ calculation of the neutral fibres
- combined bending and torsion loading by way of eccentric force application
- determination of the shear centre on a beam with a U-profile
  - ▶ familiarisation with shear flow (shear forces in a cross-section)
- comparison of calculated and measured values

# FL 160

## Unsymmetrical bending

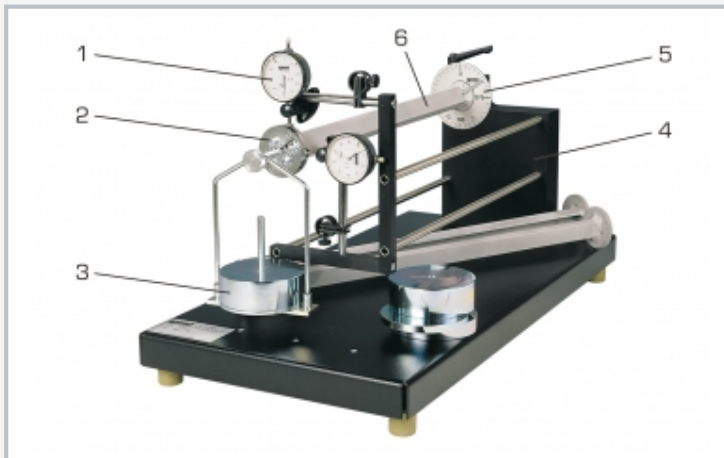

1 dial gauge, 2 device to adjust the eccentricity of the load application point and flange to mount the load, 3 weight, 4 clamping pillar, 5 clamping flange of beam with angle scale, 6 beam

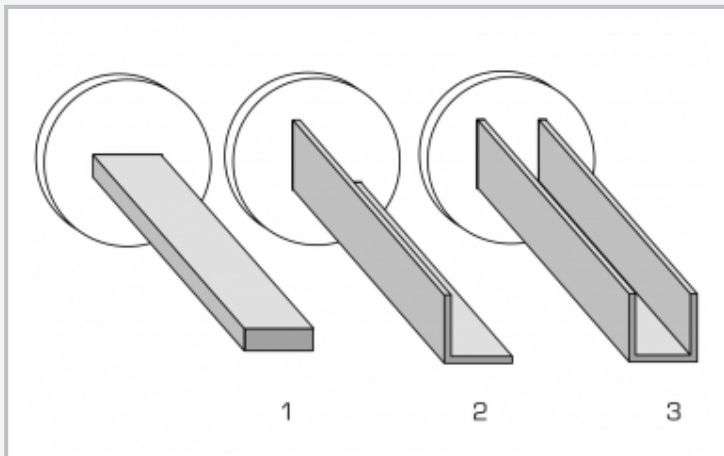

Beam: 1 I-profile, 2 L-profile, 3 U-profile

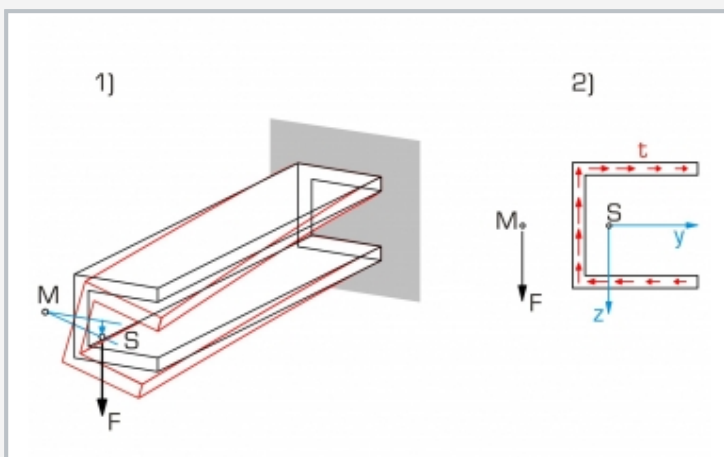

1) on application of the force at the centre of gravity the beam twists, 2) on application of the force at the shear centre no torsion occurs;  
M shear centre, S centre of gravity, F force, t shear flow

### Specification

- [1] experimental unit for general and unsymmetrical bending of straight beams
- [2] 3 beams: I, L and U profiles
- [3] clamping flange of beam can be clamped in the pillar free to rotate in any direction
- [4] clamping flange with angle scale to indicate the angular position of the beam
- [5] eccentricity of load application point adjustable
- [6] 2 dial gauges with bracket to record the horizontal and vertical deformation of the beam under load
- [7] storage system to house the components

### Technical data

Aluminium beam

- deformed length: 500mm

Eccentricity of load application point: 0...25mm

Dial gauges

- 0...10mm, graduation: 0,01mm

Angle scale

- 0...360°, graduation: 1°

Weights

- 1x 2,5N (hanger)
- 1x 2,5N
- 3x 5N

LxWxH: 700x350x400mm

Weight: approx. 25kg

LxWxH: 720x480x178mm (storage system)

### Scope of delivery

- 1 experimental unit
- 3 beams
- 2 dial gauges with bracket
- 1 set of weights
- 1 spirit level
- 1 hexagon socket wrench
- 1 storage system with foam inlay
- 1 set of instructional material

# FL 160

## Unsymmetrical bending

Optional accessories

020.30009      WP 300.09      Laboratory trolley