

LVDT

Inductive Position Transducer



SM Series

Key-Features:

- Measurement ranges 2...200 mm
- Linearity up to $\pm 0.10\%$ of full scale
- Spring loaded versions available
- Housing $\varnothing 12$ mm, clamp $\varnothing 8$ mm h6
- Protection class IP67, optional IP68
- Sensor working temperature up to 200 °C
- External, or cable electronics with cable break detection
- Customized versions available

Content:

INTRODUCTION

LVDTs (Linear Variable Differential Transformers) are inductive sensors excellent for use in harsh industrial environments, e.g. high temperature and pressure ranges, as well as high accelerations and measuring cycles.

The SM series offers ultimate reliability and precision in a small size, and is designed for industrial and lab use. The SM series is also available as a pressurized hydraulic model to 400 bar for installation directly in hydraulic cylinders. (See data sheet SM-HYD and SM-F18)

The IMCA and KAB electronics (explanation see page 5) have a built-in cable breakage monitoring and are entirely galvanically isolated. The signal output is optimized for interference compatibility with very low residual noise. The guarantee for ultimate resolution and measuring accuracy.

TECHNICAL DATA

Sensor	0...2	0...5	0...10	0...25	0...50	0...100	0...200
Measurement range FS [mm]	0...2	0...5	0...10	0...25	0...50	0...100	0...200
Linearity [% of FS]	0.30 % (0.20 % optional, 0.10 % for selected models)						
Types	spring loaded (up to range 0...100 mm), free core, push rod guided/unguided						
Protection class	IP67, optional IP68						
Vibration stability DIN IEC68T2-6	10 G						
Shock stability DIN IEC68T2-27	200 G/2 ms						
Supply voltage/ frequency	3 V _{eff} /3 kHz						
Supply frequency	2...10 kHz						
Temperature range	-40...+120 °C (150 °C optional, option H, 200 °C on request)						
Mounting	ø 8 mm h6 clamp diameter or ø 12 mm						
Housing	nickel-plated steel or stainless steel						
Connection	cable output or M12-connector with coupling nut						
cable TPE (standard)	ø 4.5 mm, 0.14 mm ² , non-halogen, suitable for drag chains						
PTFE (option H)	ø 4.8 mm, 0.24 mm ² , max. temperature 200 °C, UL Style 2895						
Max. cable length	100 m between sensor and electronics						
Spring loaded version (up to range 100 mm)							
Spring force (middle of range) [N]	0.9	0.9	0.9	0.95	0.95	1.50	-
Max. cycles of tip at 1 mm amplitude [Hz]	55	50	50	35	20	15	-
Life cycle	> 10 million cycles						
Free core/ push rod/ push rod guided							
Max. acceleration of core/ push rod	100 G						
Life cycle	infinite						
Weight (approx., without cable) [g]	36	42	47	59	85	136	238

Electronics	IMCA external electronics (built-in)	KAB cable electronics
Output signal	0...20 mA, 4...20 mA (load < 300 Ohm) 0...5 V, ± 5 V (load > 5 kOhm) 0...10 V, ± 10 V (load > 10 kOhm)	4...20 mA (load < 300 Ohm) 0...5 V, ± 5 V (load > 5 kOhm) 0...10 V, ± 10 V (load > 10 kOhm)
Temperature coefficient	-0.0055, ±0.002 %/K	
Resolution*	0.04% of FS	
Corner frequency	300 Hz/-3 dB (6-pole Bessel)	
Isolation stability	> 1000 VDC	
Power supply	9...36 VDC	
Current consumption	75 mA at 24 VDC 150 mA at 12 VDC	65 mA at 24 VDC 140 mA at 12 VDC
Sensor supply	3 V _{eff} , 3 kHz (adjustable, 1-18 kHz)	
Working temperature	-40...+85 °C	
Storage temperature	-40...+85 °C	
Housing	polyamide PA6.6, meets UL94-VO	ABS
Mounting	on DIN EN-rail	bore diameter ø 5,5

* 98.5% confidence interval (confidence limit)

TECHNICAL DIMENSIONS

range (FS) [mm]	body length B radial cable/ connector [mm]	body length C connector M12[mm]	core length D [mm]	push rod length E [mm]
0...2	64	67	22	54
0...5	70	73	25	60
0...10	80	83	30	70
0...25	110	113	45	100
0...50	160	163	70	150
0...100	260	263	120	250
0...200	460	463	220	450

Other measurement ranges are available on request.

type:

free core: delivery D: core (the core extension made of non-magnetic material must be added by the customer).

push rod unguided: delivery E: core + core extension

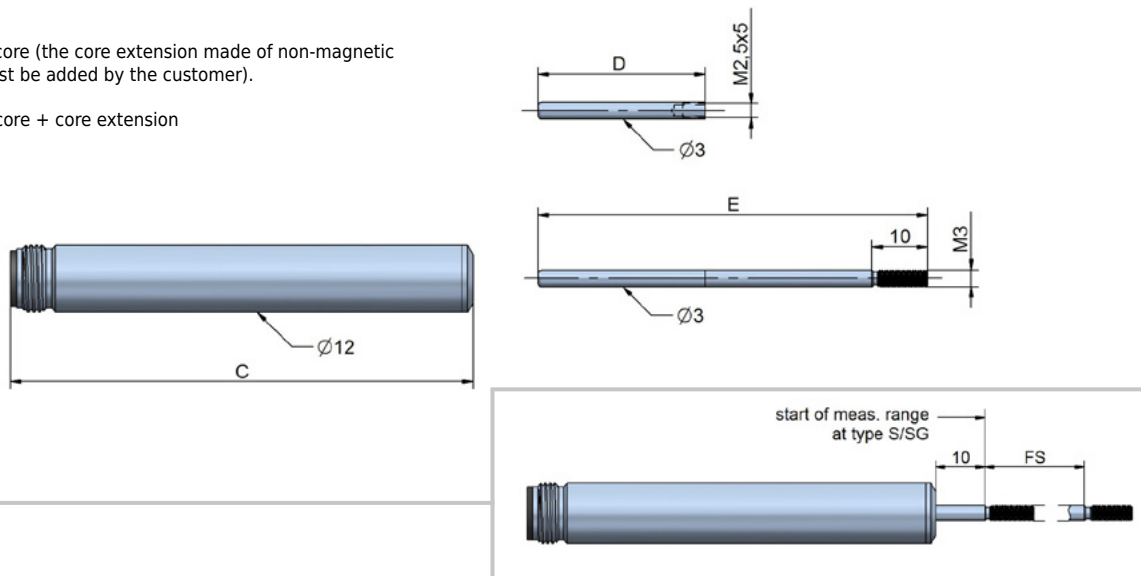

type: push rod guided

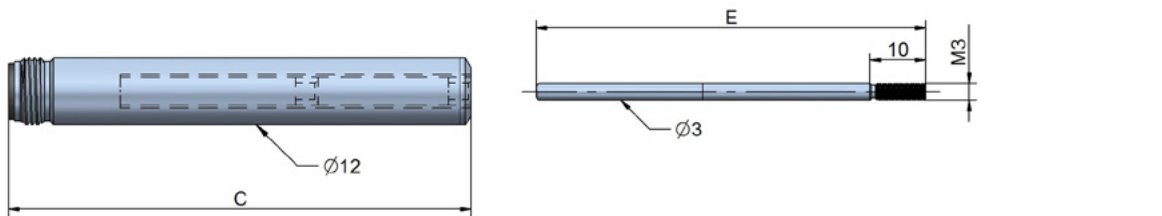

type:

spring loaded (up to range 0...100 mm)

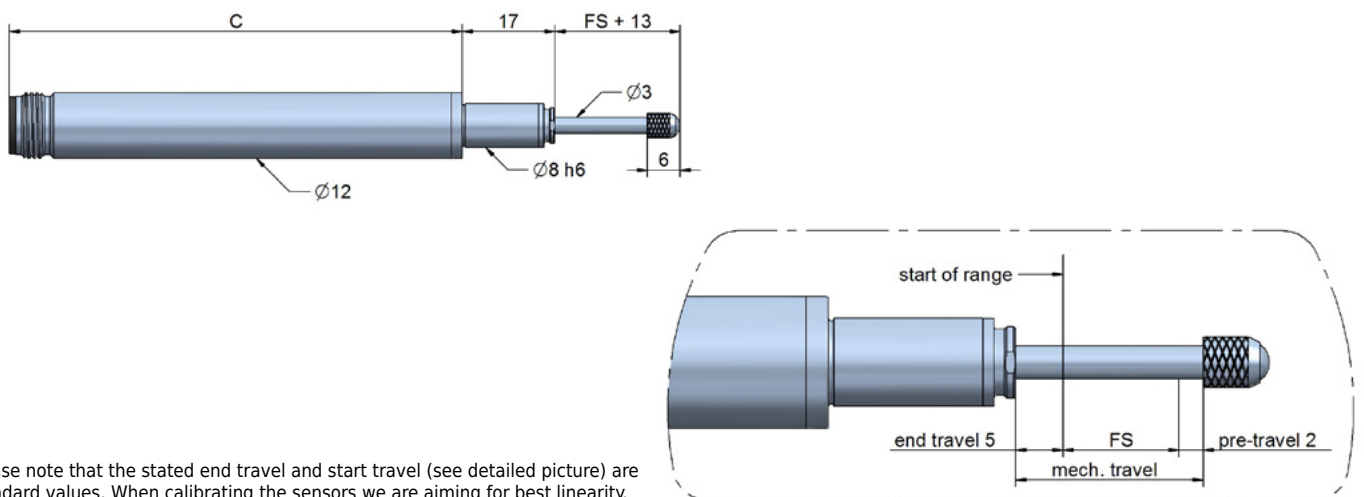

Please note that the stated end travel and start travel (see detailed picture) are standard values. When calibrating the sensors we are aiming for best linearity.

SENSOR TYPES

axial cable output

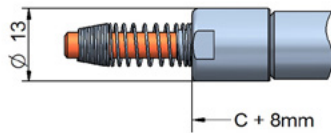

Sensors with cable output have a cable fitting and a spring for bend protection of the cable.

For installation, the bending radius should not be less than 3 times the cable diameter. The standard cable length is 2 m.

Instruments with option H for temperatures up to 150 °C/ 200°C feature a PTFE cable.

radial cable/ connector output

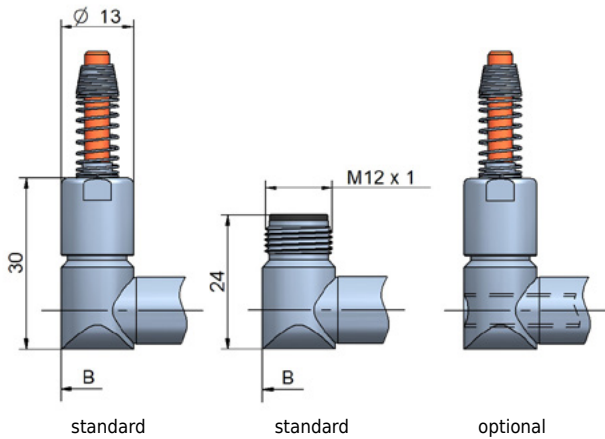

For normal application the sensors have a closed rear end body.

Sensors that feature a radial cable output can be supplied with a through hole on request (option RO). Please use this version for applications at heavy dirt exposure. The movement of the push rod removes dirt from the sensor and conveys it to the rear. The standard cable length is 2 m.

connector output (cable with straight or angular connector)

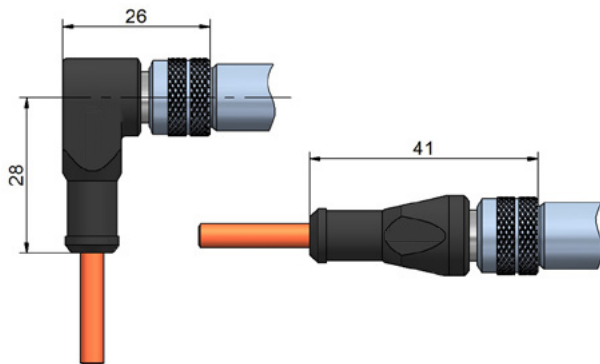

For sensors with connector output the cable has to be ordered separately. You can choose from a cable with a straight connector or with an angular connector.

The connector is protected from accidental removal by a threaded fitting (M12). The cable lengths are 2/ 5/ 10 m.

The connector pair has protection class IP67.

The total length of the sensor with connector is:
body length of the connector M12 (see table) + 20 mm (angular connector)
body length of the connector M12 (see table) + 37 mm (straight connector)

gaiter (option FB for SM2...SM25)



A gaiter is available for spring loaded sensors to protect the mechanics from fouling.

Note: The gaiter is also available as retrofit kit for measurement ranges from 2 to 25 mm.

- The measurement range of sensors with 25 mm is reduced to 20 mm!
- The working temperature is limited to 0...+120 °C.

rod seal / wiper

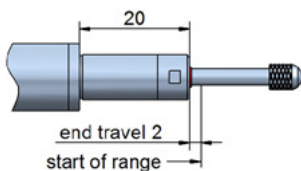

A special design of a fluorocarbon sealing integrated in the sensor front cap combines sealing and wiping and ensures a smooth motion of the mechanics.

Note: The end travel is reduced to 2 mm!

AC-OUTPUT

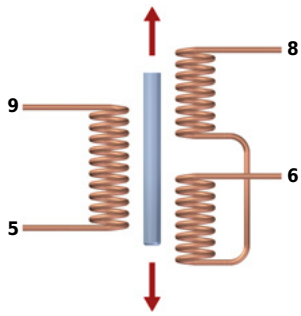

assignment for TPE-cable:

white (5): primary 2
 black (6): secondary 2
 brown (9): primary 1
 blue (8): secondary 1

assignment for PTFE-cable:

white (5): primary 2
 green (6): secondary 2
 yellow (9): primary 1
 brown (8): secondary 1

assignment M12-connector:

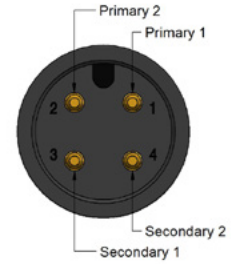

CABLE ELECTRONICS KAB

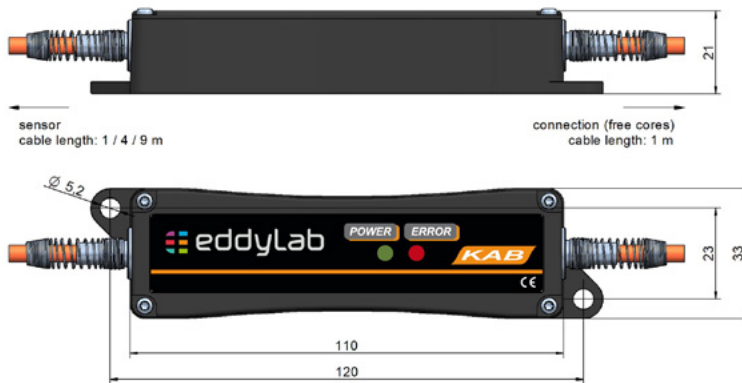

function	cable TPE	cable PTFE-UL
V+	brown	yellow
GND	blue	brown
signal	white	white
signal GND	black	green

If not specified otherwise the cable electronics is placed at 1 m from the end of the cable.

EXTERNAL ELECTRONICS IMCA



external electronics IMCA (for DIN-rail mounting)

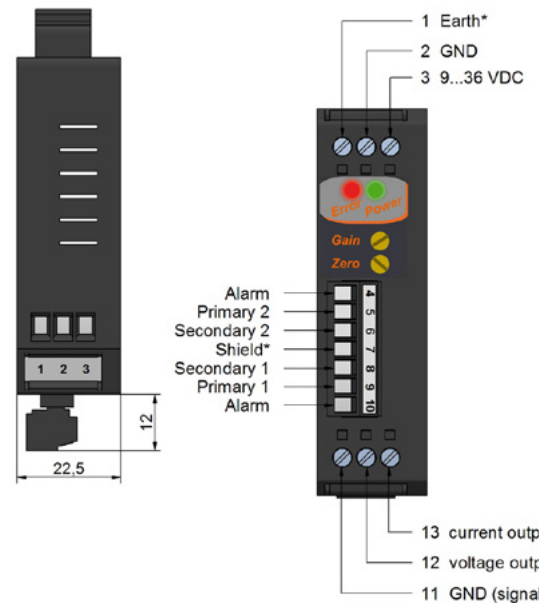
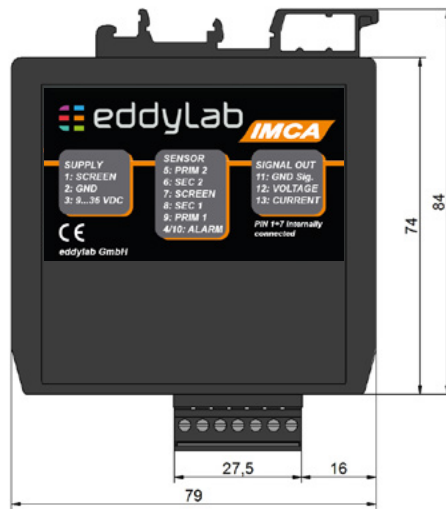

Connection

The external electronics IMCA is designed to be installed in switch cabinets (Din-rail mounting). The connection to the sensor is conducted as connector with push-in spring connection.

At harsh EMC environments, it is possible to install the electronics at a max. distance of 100 m in a switch cabinet. A twin twisted pair cable (4-cores, minimum cross section 0,5 mm²), single or double shielded, is to be used for the further wiring to connect the external electronics to the system. It is recommended to ground the shield in the switch cabinet near the electronics (do not ground at the machine/ sensor). The sensor housing is grounded at the machine frame. To prevent interference, the cable length should not exceed 100 m.

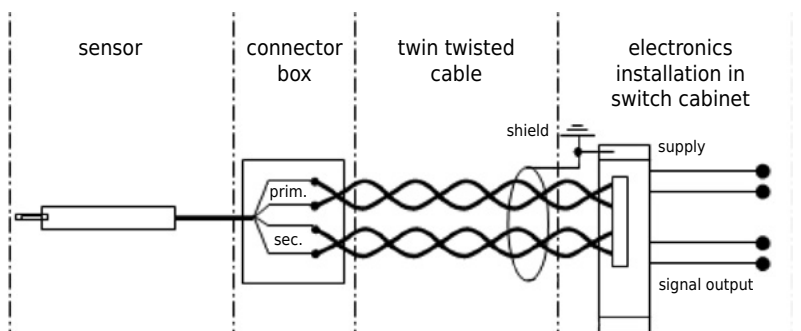

ADJUSTMENT OF ZERO POINT AND GAIN

Please note that the zero point and gain may shift for long cable length between sensor and electronics. Thus install the sensor with the according cable length to the electronics and then adjust zero point and gain.

1. Push rod entirely in - adjust offset.
Move the sensor to the zero point of the measuring range and set the offset potentiometer on 4 mA/0 V for the output signal.
2. Push rod entirely out - adjust gain
Move the sensor to the end of the measuring range (push rod moved out) and set the gain potentiometer on 20 mA /10 V/5 V for the output signal.

Signal inversion:

If an inverted output signal is required (20...4 mA /10...0 V/5...0 V), swap clamps 6 and 8 (secondary coil) on the external electronics.

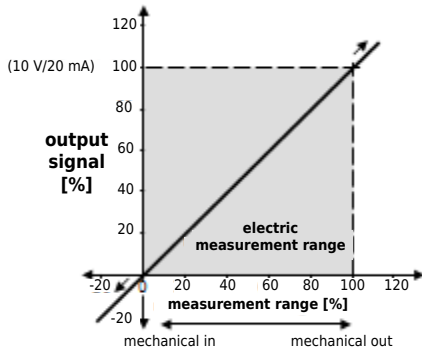

The output signal is referring to the electric measuring range. If the sensor is operated outside the measuring range or the measuring range is exceeded, the signal is also outside the defined range (i.e. > 10 V/20 mA or < 0 V/4 mA, in the graph: > 100 % or < 0 %). Please keep this in mind for control systems with cable break detection lower than 4 mA or for a maximum input voltage > 10 V of measuring instruments. If necessary install the sensor **before** connecting to the PLC.

Running direction of signal: If the push rod is moving into the sensor (e.g. sprung load pushed in), the signal is reducing. If the push rod is moving out, the output signal is increasing. The running direction of the signal can also be inverted.

CABLE BREAK DETECTION

The electronics by eddylab feature a built-in cable break detection. This is achieved by an impedance measurement of the LVDT's secondary coil. If the sensor cable is cut, the impedance on the secondary connections of the electronics change regardless of the push rod position, triggering the cable break detection. This feature is based on a broken secondary connection. A partial cable break of the primary connections (cables between primary coil and electronics) will not activate this function. The electronics vary in their functional range. The external electronics IMCA offers the widest range. The cable electronics KAB only visualises a cable break by a red LED.

IMCA: For the use of the cable break functions an alarm system (signal lamp, acoustic alarm device) or an alarm input of the PLC must be connected to the 7-pole terminal. The circuit board features a analog switch which is a normally open.

Normal operation IMCA:

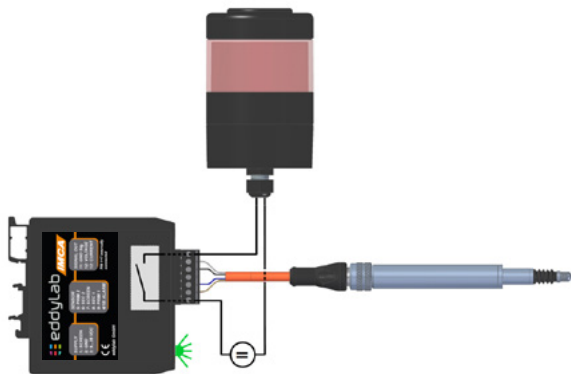

- The green „POWER-LED“ on the front side is on.
- The signal output is active.
- The alarm output is disabled.

Cable break IMCA:

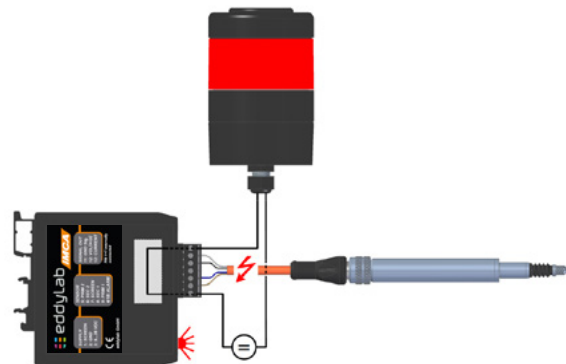

- In case of a cable break the analog switch closes and the alarm system is activated or an electrical signal is conducted. Please note the maximum electrical values: 30 mA or 14 V.
- A front side „ERROR-LED“ flashes in case of an error.
- The signal output is deactivated. There is no current or voltage signal.

Normal operation KAB:



- The green „POWER-LED“ is on.

Cable break KAB:

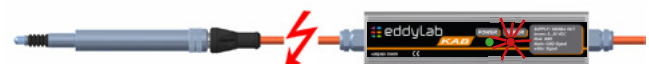

- The red „ERROR-LED“ is on.

FEELER FOR SPRING LOADED VERSION

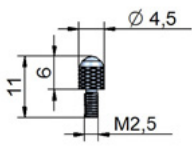
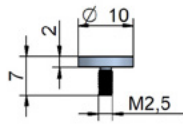
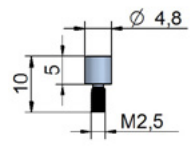
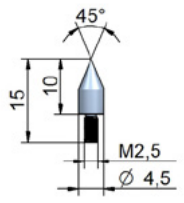
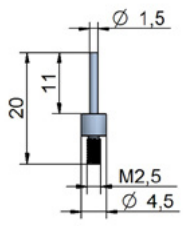
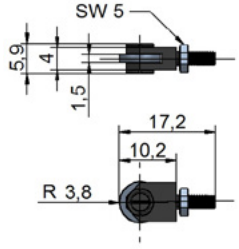
<p>Tastkopf-01, steel (standard) Tastkopf-01-HM, cemented carbide Tastkopf-01-R, ruby Tastkopf-01-K, ceramics</p> 	<p>Tastkopf-02, steel Tastkopf-02-HM, cemented carbide</p> 	<p>Tastkopf-03, steel Tastkopf-03-HM, cemented carbide</p> 
<p>Tastkopf-04, steel</p> 	<p>Tastkopf-05, steel</p> 	<p>Tastkopf-782.238, roller</p> 

Material of Tastkopf-01 feeler balls:

steel: for standard applications
 ruby: much harder and wear resistant than steel, non-conductive, for all applications except for measuring on aluminium and cast iron
 ceramics: comparable to ruby, best choice for measuring on aluminium and cast iron

MOUNTING PARTS

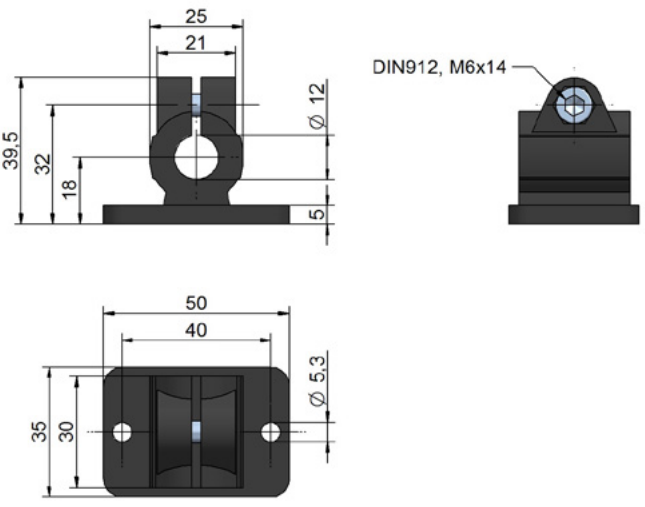
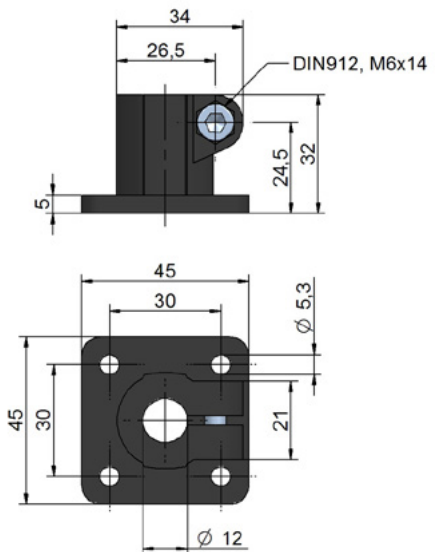
<p>Flanschklemmstück 1218: flange clamp $\varnothing 12$ mm for SM-series material: reinforced polyamide $\varnothing 18$ mm without reducing bush, $\varnothing 12$ mm with reducing bush (included)</p> 	<p>Fußklemmstück 1218: base clamp $\varnothing 12$ mm for SM-series material: reinforced polyamide $\varnothing 18$ mm without reducing bush, $\varnothing 12$ mm with reducing bush (included)</p> 
---	--

ORDER CODE SENSOR

SM **X** - **X** - **X** - **X** **X** **X** **X** **X** **X** **X** **X**
a **b** **c** **d** **e** **f** **g** **h** **i** **j**

a measurement ranges [mm]

2 / 5 / 10 / 25 /
 50 / 100 / 200

b type

A = free core
 S = unguided push rod
 SG = guided push rod
 T = spring loaded

c cable/ connector

KA = axial cable output
 KR = radial cable output
 SA = axial connector output M12
 SR = radial connector output M12

d cable / connector output

S1: sensor with connector output

1 = connector output M12 (no cable)

S2: sensor with cable output, open cable end (for IMCA)

A = TPE cable 2 m
 B = TPE cable 5 m
 C = TPE cable 10 m
 D = PTFE-UL cable 2 m (option H)
 E = PTFE-UL cable 5 m (option H)
 F = PTFE-UL cable 10 m (option H)

S3: sensor with cable output for KAB

G = TPE cable 2 m
 H = TPE cable 5 m
 J = TPE cable 10 m
 K = PTFE-UL cable 2 m (option H)
 L = PTFE-UL cable 5 m (option H)
 M = PTFE-UL cable 10 m (option H)

e linearity

1 = 0,30 % (standard)
 2 = 0,20 % (option L20)
 3 = 0,10 % (option L10)

f temperature range

1 = -40...+120 °C (standard)
 2 = -40...+150 °C (option H)
 3 = -40...+200 °C (option H200)

g push rod sealing

1 = - (standard)
 2 = gaiter (option FB)
 2 = wiper ring (option W)

h protection class

1 = IP67
 2 = IP68 (option IP68)

i housing

1 = chrome-plated steel
 2 = stainless steel 1.4301 (option VA)

j spring force

1 = for type „A/S/SG“
 2 = standard
 3 = HD2.5 (approx. 250g)
 4 = HD (approx. 500g)

ORDER CODE ELECTRONICS

IMCA - 24V - **X**
a

KAB - 24V - **X** - **X**
a **b**

type

IMCA = external electronics
 KAB = cable electronics

a output signal

020A = 0...20 mA
 420A = 4...20 mA
 10V = 0...10 V
 5V = 0...5 V
 ±5V = -5...5 V
 ±10V = -10...10 V

b KAB: type of cable / cable length

E1: for sensor with cable output

- = KAB integrated in sensor cable

E2: for sensor with connector output

A = cable 2 m, M12 straight female connector
 B = cable 2 m, M12 angular female connector
 C = cable 5 m, M12 straight female connector
 D = cable 5 m, M12 angular female connector
 E = cable 10 m, M12 straight female connector
 F = cable 10 m, M12 angular female connector

possible combinations:

- S1: sensor with connector output
- S2: sensor with cable output
- S3+E1: sensor with cable output, KAB integrated in sensor cable

- S1+E2: sensor with connector output, cable electronics with cable K4PxM
- S1+E3: sensor with cable output, cable K4PxM, external electronics IMCA
- S2+E3: sensor with cable output, external electronics IMCA

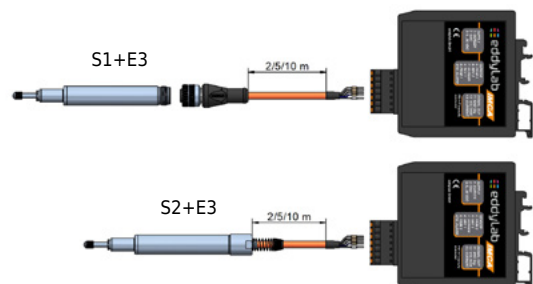
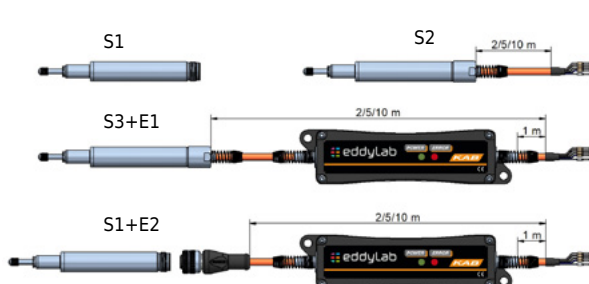

Subject to change without prior notice.