

LVDT

Inductive Position Transducer



SLX-series

designed for pharmaceutical, medical
and food industry

Key-Features:

- stainless steel housing
- high protection class IP68/IP69K
- pressure-tight up to 20 bar
- high chemical resistance
- linearity up to $\pm 0,10$ % of measurement range
- working temperature of sensor up to 150 °C

content:

Cable Break Detection

...6
...7

INTRODUCTION

LVDTs (Linear Variable Differential Transformers) are inductive sensors excellent for use in harsh industrial environments, e.g. high temperature and pressure ranges, as well as high accelerations and measuring cycles.

The SLX-series is based on the rugged SL-series and is perfectly adapted to the environmental conditions in pharmaceutical, medical and food industry applications. Today CIP and SIP („clean in place“, „sterilisation in place“) are state-of-the-art processes to ensure a hygienic production, starting from grade „clean“ up to „aseptic“. Therefore all interior surfaces and parts of the machines will be cleaned using aggressive mediums at high temperatures and pressure. The SLX-series is built to withstand these challenging conditions and guarantees highest reliability and life-time.

TECHNICAL DATA

Sensor								
Measurement range [mm]	0...10	0...25	0...50	0...80	0...100	0...150	0...200	0...300
Linearity [% of range]	0,30 %, optional 0,20 %, 0,10 % for selected models							
Type	free core, push rod guided/ unguided, rod end bearings							
Protection class	IP68 / IP69K							
Vibration stability DIN IEC68T2-6	10 G							
Shock stability DIN IEC68T2-27	200 G/ 2 ms							
Supply voltage/ frequency	3 V _{eff} / 12 kHz							
Supply frequency	2...10 kHz							
Temperature range	-40...+150 °C (option H200 up to 200 °C)							
Mounting	ø 20 mm clamp diameter or rod end bearings							
Housing	stainless steel 1.4571 / 1.4301							
Connection	4 core shielded cable							
PTFE	material FEP, ø 4,8 mm, 4x0,24 mm ² , max. temperature 205 °C, UL-Style 2895, 200°C/300V							
Max. cable length	2 m							
Free core/ push rod/ rod end bearings								
Max. acceleration of core/ push rod	100 G							
Life cycle	infinite							
Weight (approx., without cable) [g]	125	150	230	290	320	360	420	550

Electronics	IMCA external electronics (built-in)	KAB cable electronics
Output signal	0...20 mA, 4...20 mA (load <300 Ohm) 0...5 V, ± 5 V (load >5 kOhm) 0...10 V, ± 10 V (load >10 kOhm)	4...20 mA (load <300 Ohm) 0...5 V, ± 5 V (load >5 kOhm) 0...10 V, ± 10 V (load >10 kOhm)
Temperature coefficient	-0,0055, ±0,002 %/K	
Resolution*	0,04 % FS	
Corner frequency	300 Hz/-3 dB (6-pole Bessel)	
Isolation stability	> 1000 VDC	
Power supply	9...36 VDC	
Current consumption	75 mA at 24 VDC 150 mA at 12 VDC	65 mA at 24 VDC 140 mA at 12 VDC
Sensor supply	3 V _{eff} , 3 kHz (adjustable, 1-18 kHz)	
Working temperature	-40...+85 °C	
Storage temperature	-40...+85 °C	
Housing	polyamide PA6.6, meets UL94-VO	ABS
Mounting	on DIN EN-rail	bore diameter ø 5,5

* 98.5% confidence interval (confidence limit)

CHEMICAL RESISTANCE

Medium	concentration [%]	temperature [°C]	resistance
acetic acid + hydrogen peroxide	10 and 50	20	•
		50	•
		90	•
ammoniac			•
ammonium chloride	10	boiling	•
	25	boiling	•
ammonium hydroxide	any	20	•
		boiling	•
caustic soda	25	20	•
		boiling	•
citric acid	up to 10	20	•
		boiling	•
	up to 50	20	•
		5 (3 bar)	140
formic acid	10	20	•
		70	•
	100	20	•
hydrogen peroxide	up to 2	90	•
	10	20	•
hypochloric acid	0,5	20	•
nitric acid	7	20 or boiling	•
	10	20 or boiling	•
	25	20 or boiling	•
	37	20 or boiling	•
	50	20 or boiling	•
	66	20 or boiling	•
peracetic acid	6	60	•
phosphoric acid	1	20	•
		boiling	•
	10	20	•
		boiling	•
	45	20	•
	60	20	•
	70	20	•
	80	20	•
	concentrated	20	•
saltwater *	-	20	•
sodium hypochlorite	5	20	•
		boiling	•
steam	-	up to 150	•
steam with SO ₂ / CO ₂			•
sulphuric acid	1	20	•
		70	•
		boiling	•
	up to 7,5	20	•
		70	•
		up to 98 %	20

* possible pitting corrosion

Information about further chemicals on request.

AC OUTPUT

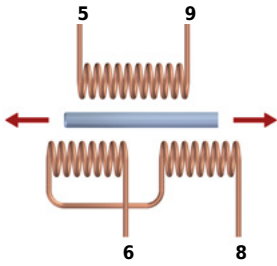

assignment for PTFE-cable:

- | | |
|-------------|-------------|
| white (5): | primary 2 |
| green (6): | secondary 2 |
| yellow (9): | primary 1 |
| brown (8): | secondary 1 |

CABLE ELECTRONICS KAB

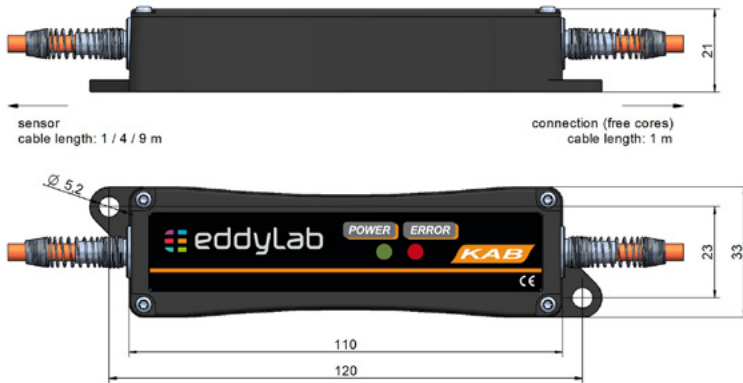

function	cable TPE	cable PTFE-UL
V+	brown	yellow
GND	blue	brown
signal	white	white
signal GND	black	green

If not specified otherwise the cable electronics is placed at 1 m from the end of the cable.

EXTERNAL ELECTRONICS IMCA



external electronics IMCA (for DIN-rail mounting)

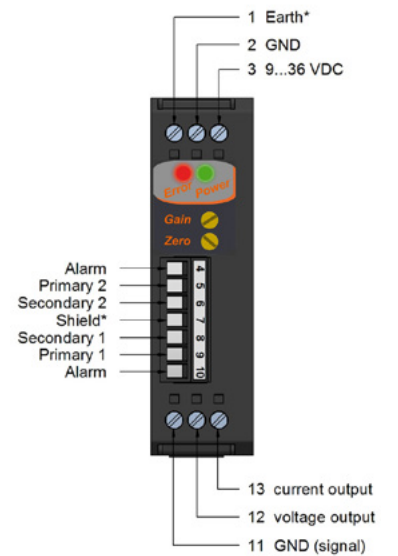
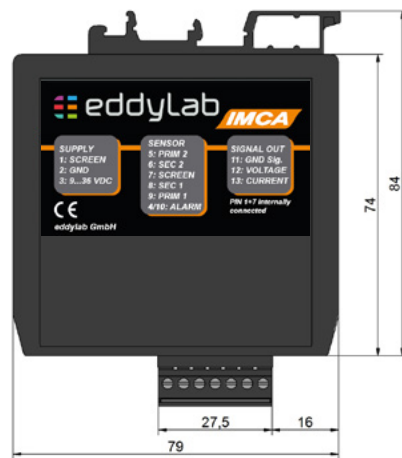

Connection

The external electronics IMCA is designed to be installed in switch cabinets (Din-rail mounting). The connection to the sensor is conducted as connector with push-in spring connection.

At harsh EMC environments, it is possible to install the electronics at a max. distance of 100 m in a switch cabinet. A twin twisted pair cable (4-cores, minimum cross section 0,5 mm²), single or double shielded, is to be used for the further wiring to connect the external electronics to the system. It is recommended to ground the shield in the switch cabinet near the electronics (do not ground at the machine/ sensor). The sensor housing is grounded at the machine frame. To prevent interference, the cable length should not exceed 100 m.

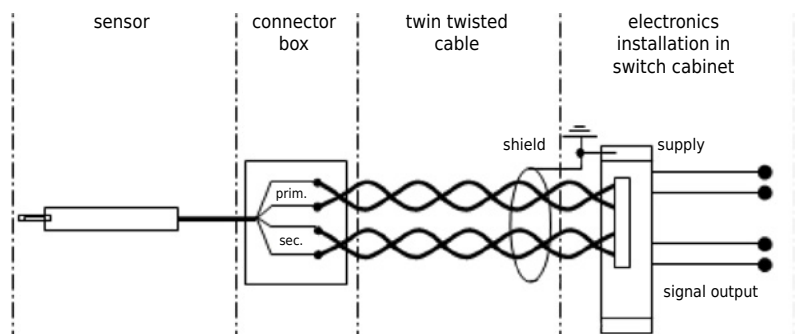

ADJUSTMENT OF ZERO POINT AND GAIN

Please note that the zero point and gain may shift for long cable length between sensor and electronics. Thus install the sensor with the according cable length to the electronics and then adjust zero point and gain.

1. Push rod entirely in - adjust offset
Move the sensor to the zero point of the measuring range and set the offset potentiometer on 4 mA/0 V for the output signal.
2. Push rod entirely out - adjust gain
Move the sensor to the end of the measuring range (push rod moved out) and set the gain potentiometer on 20 mA /10 V/5 V for the output signal.

Signal inversion: If an inverted output signal is required (20...4 mA/10...0 V/5...0 V), swap clamps 6 and 8 (secondary coil) on the external electronics.

CABLE BREAK DETECTION

The electronics by eddylab feature a built-in cable break detection. This is achieved by an impedance measurement of the LVDT's secondary coil. If the sensor cable is cut, the impedance on the secondary connections of the electronics change regardless of the push rod position, triggering the cable break detection. This feature is based on a broken secondary connection. A partial cable break of the primary connections (cables between primary coil and electronics) will not activate this function. The electronics vary in their functional range. The external electronics IMCA offers the widest range. The cable electronics KAB only visualises a cable break by a red LED.

IMCA: For the use of the cable break functions an alarm system (signal lamp, acoustic alarm device) or an alarm input of the PLC must be connected to the 7-pole terminal. The circuit board features a analog switch which is a normally open.

Normal operation IMCA:

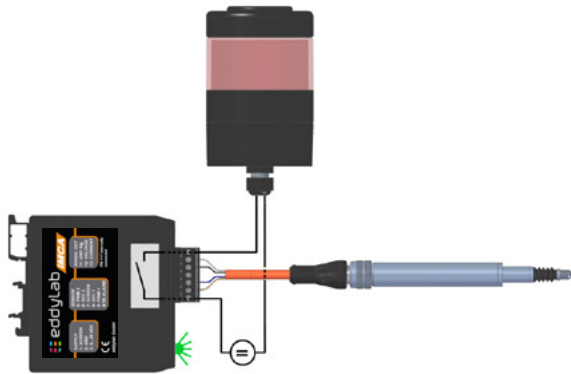

- The green „POWER-LED“ on the front side is on.
- The signal output is active.
- The alarm output is disabled.

Cable break IMCA:

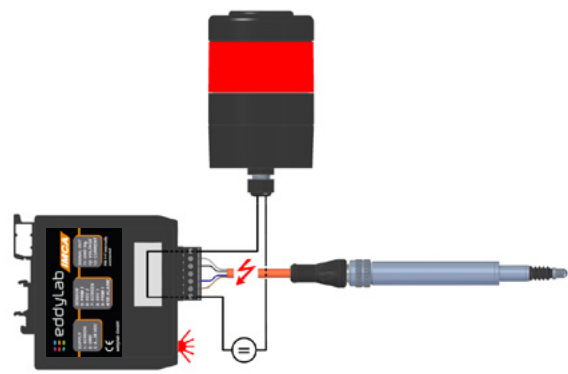

- In case of a cable break the analog switch closes and the alarm system is activated or an electrical signal is conducted. Please note the maximum electrical values: 30 mA or 14 V.
- A front side „ERROR-LED“ flashes in case of an error.
- The signal output is deactivated. There is no current or voltage signal.

Normal operation KAB:

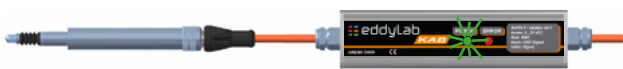

- The green „POWER-LED“ is on.

Cable break KAB:



- The red „ERROR-LED“ is on.

ORDER CODE SENSOR

SLX **X** - **X** - **X** - **X** **X** **X** **X** **X**
a **b** **c** **d** **e** **f** **g**

a measurement ranges [mm]

10 / 25 / 50 / 80 /
 100 / 150 / 200 / 300 /

b type

A = free core
 S = unguided push rod
 SG = guided push rod
 G = rod end bearings

c cable/ connector

KR = radial cable

d cable / connector output

S2: sensor with cable output, open cable end (for IMCA)

D = PTFE-UL cable 2 m (option H)
 E = PTFE-UL cable 5 m (option H)
 F = PTFE-UL cable 10 m (option H)

S3: sensor with cable output for KAB

K = PTFE-UL cable 2 m (option H)
 L = PTFE-UL cable 5 m (option H)
 M = PTFE-UL cable 10 m (option H)

e linearity

1 = 0,30 % (standard)
 2 = 0,20 % (option L20)
 3 = 0,10 % (option L10)

f temperature range

1 = -40...+150 °C (standard)
 2 = -40...+200 °C (option H200)

g push rod sealing

1 = - (standard)
 2 = wiper ring (option W)

ORDER CODE ELECTRONICS

IMCA - 24V - **X**
a

KAB - 24V - **X** - **X**
a **b**

type

IMCA = external electronics
 KAB = cable electronics

a output signal

020A = 0...20 mA
 420A = 4...20 mA
 10V = 0...10 V
 5V = 0...5 V
 ±5V = -5...5 V
 ±10V = -10...10 V

b KAB: type of cable / cable length

E1: for sensor with cable output

- = KAB integrated in sensor cable

combination options:

- S2: sensor with cable output
- S3+E1: sensor with cable output, KAB integrated in sensor cable
- S2+E3: sensor with cable output, external electronics IMCA
-

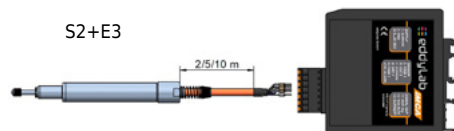
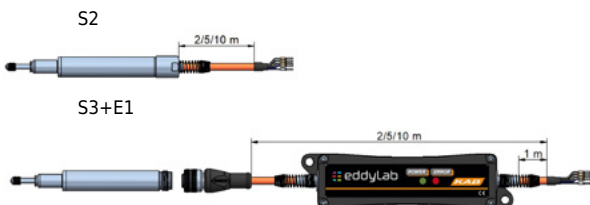



Subject to change without prior notice.