

# SE 110.21

## Forces in various single plane trusses

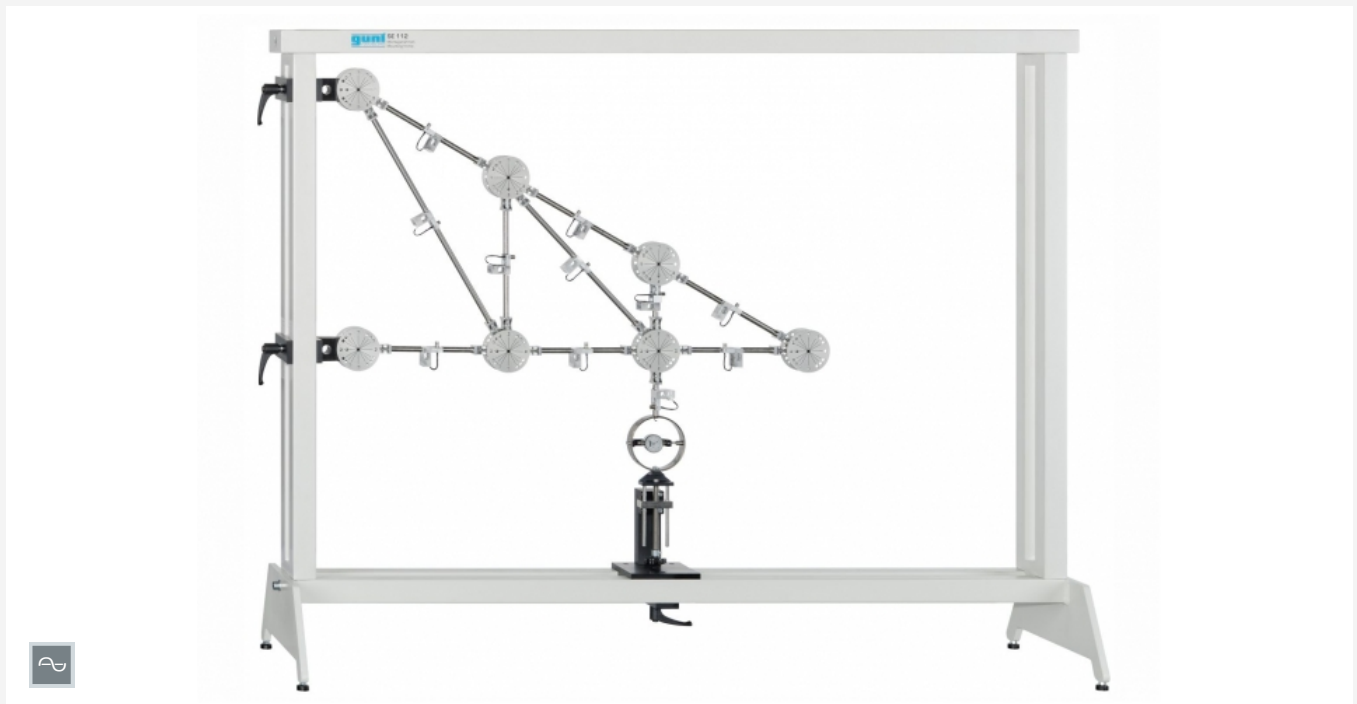

The illustration shows SE 110.21 in the frame SE 112.

### Description

- measurement of the bar forces in a single plane truss
- construction of various truss forms
- bars with strain gauge measurement to measure bar force

As light-weight structures offering a high degree of rigidity, trusses are employed in the construction of halls, bridges, cranes, pylons and masts. Trusses are bar structures in which the bars are subjected to compression or tension loading, but not to bending.

The object of the experiment is to measure the bar forces in a single plane truss subjected to a single external force. The SE 110.21 experimental setup features bars with special snap-lock closures on their ends allowing them to be fixed easily into the node disk. The range of different bar lengths provided permits three statically determinated truss to be constructed.

The bars are hinged, joined together by node disks, and are subjected only to compressive or tensile stress. No moments are transmitted in the nodes; they can be regarded as frictionless.

Consequently, our trusses can be considered as ideal trusses. A load application device attached to a node disk generates an external force. All the forces on the truss bars are recorded by means of strain gauge measurement. Computerised evaluation of the measured values is provided by measuring amplifier FL 152 (16 input channels). The software in FL 152 is used to manage the measured data and provide graphical representation of the bar forces. The software features a comprehensive help function.

All the component elements of the experiment are clearly laid-out and housed securely in a storage system. The complete experimental setup is arranged in the frame SE 112.

### Learning objectives/experiments

- measurement of the bar forces in various single plane trusses
- dependency of the bar forces on the external force
  - ▶ magnitude
  - ▶ direction
  - ▶ point of application
- comparison of measuring results with mathematical methods
  - ▶ method of joints
  - ▶ Ritter's method of sections
- basic principle: measurement of forces using strain gauge measurement

# SE 110.21

## Forces in various single plane trusses

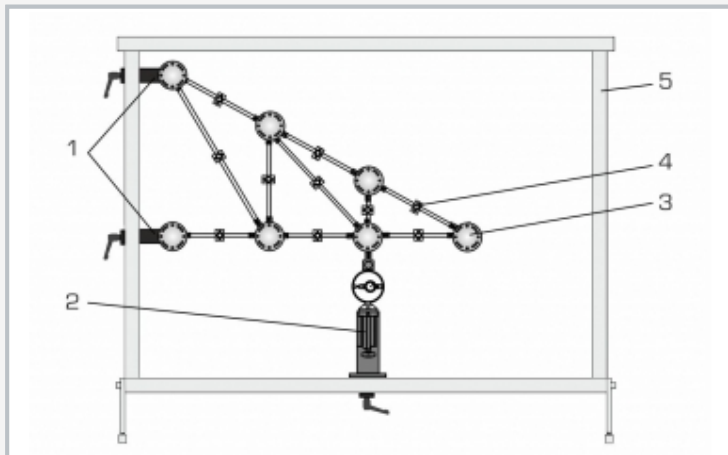

1 support, 2 load application device with force gauge, 3 node disk, 4 bar with measuring point, 5 frame SE 112

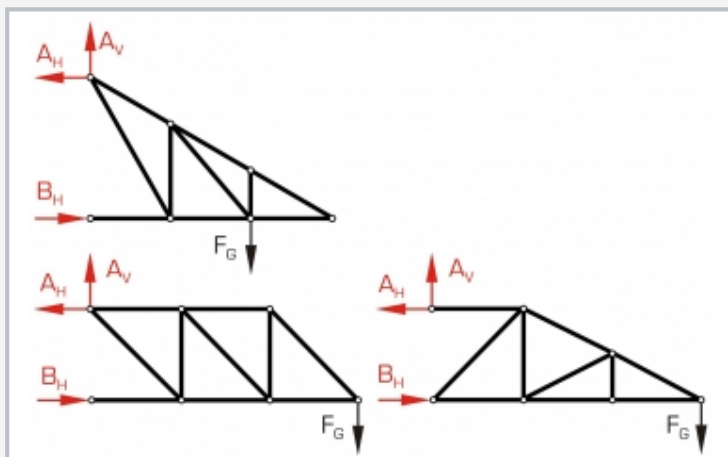

3 truss forms  
red: support reactions, black: external force

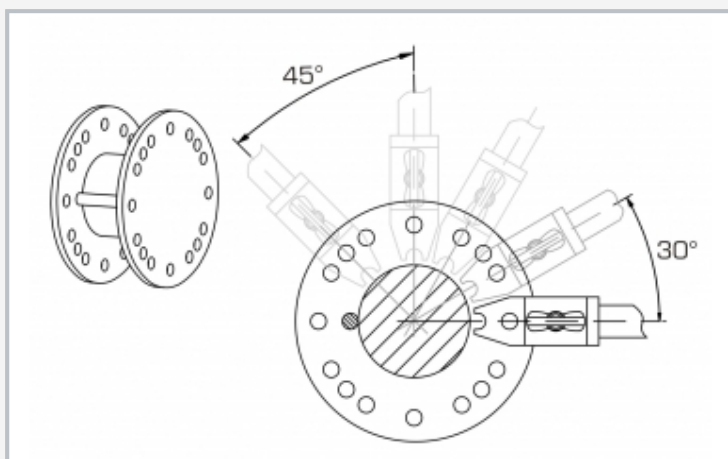

Fixing of the bars in the node disk

### Specification

- [1] investigation of bar forces in a statically determinate truss
- [2] construction of various trusses possible
- [3] 2 supports with node disks
- [4] load application device with force gauge mountable on different node disks
- [5] measuring points to measure force on each bar
- [6] measuring amplifier FL 152 required
- [7] GUNT-software in FL 152 to evaluate measured values graphically
- [8] storage system to house the components
- [9] experimental setup in frame SE 112

### Technical data

Bars: 19

- 2 bars 150mm
- 5 bars 259mm
- 7 bars 300mm
- 1 bar 397mm
- 3 bars 424mm
- 1 bar 520mm
- angle between bars: 30°, 45°, 60°, 90°
- maximum bar force: 500N
- measuring points on each bar
- height of truss max. 450mm
- length of truss max. 900mm

Load application device

- ±500N
- graduation: 10N

LxWxH: 1170x480x178mm (storage system)

Weight: approx. 26kg (total)

### Scope of delivery

- 1 set of bars
- 5 node disks
- 2 supports with node disk
- 1 load application device
- 1 set of cables
- 1 storage system with foam inlay
- 1 set of instructional material

## **SE 110.21**

### **Forces in various single plane trusses**

Required accessories

021.15200	FL 152	Multi-channel measuring amplifier
022.11200	SE 112	Mounting frame