

## SE 110.53

### Equilibrium in a single plane, statically determinate system



The illustration shows SE 110.53 in the frame SE 112.

#### Description

##### ■ equilibrium conditions and support reactions of a leaning ladder

The principle of “freeing” in engineering mechanics allows forces and moments acting on a body to be made visible. In this process, a body or a system such as a bar are virtually removed from the environment. All forces acting on the body or on the system are replaced by standardised symbols. This results in a simplified model of the body or system, which clearly demonstrates the relationships between forces and moments.

In the experiment SE 110.53, we demonstrate the principle of “freeing”, which refers to establishing static equilibrium. The experiment uses a model of a ladder with a sliding clamp weight.

The top support is designed as a movable support and the bottom one as a fixed support. The real effective support forces can be fully compensated by applying cable forces in the x and y directions.

The ladder is in a state of equilibrium without changing the angular position and without the need for structural support. The ladder is “free”. For students, the result is a convincing example for the principle of “freeing” in statics.

The parts of the experiment are clearly laid out and securely housed in a storage system. The entire experimental setup is constructed in the SE 112 mounting frame.

#### Learning objectives/experiments

- experimental development of the core principle of “freeing” in statics
- calculation of the support forces for a given position of the clamp weight and for a known angle of inclination
- application of the 1<sup>st</sup> and 2<sup>nd</sup> equilibrium conditions in statics
- and full compensation of the support forces by cable forces
- how does the clamp weight position affect the support forces
- how the angle of inclination affects the support forces

# SE 110.53

## Equilibrium in a single plane, statically determinate system

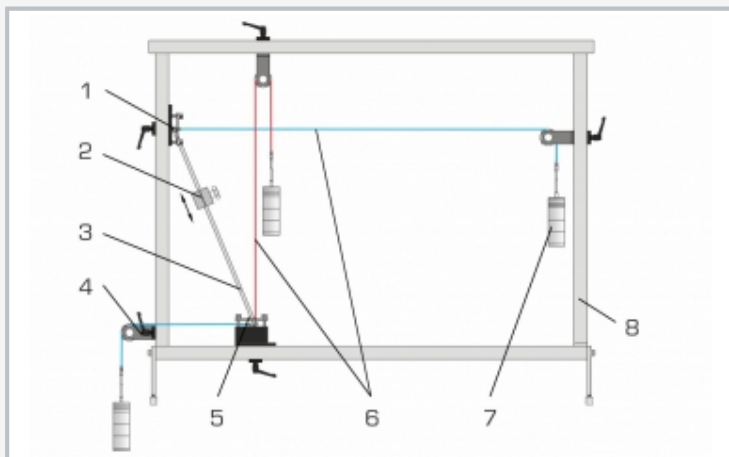

1 support (movable support), 2 clamp weight, 3 ladder, 4 clamp guide pulley, 5 support (fixed support), 6 cable, 7 weight, 8 SE 112 mounting frame

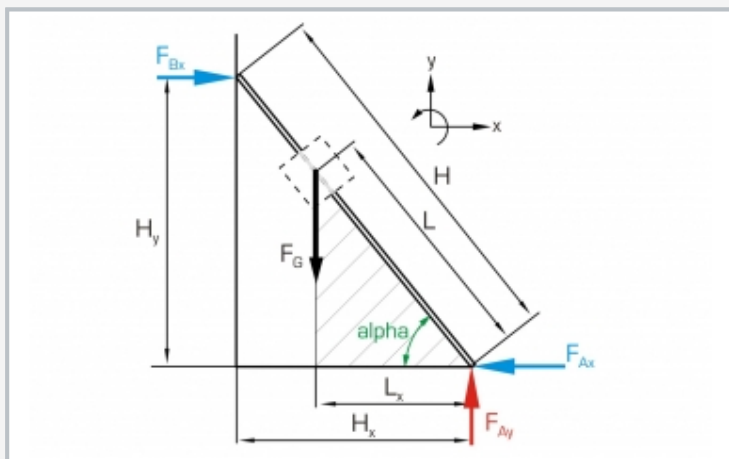

Free-body diagram of the leaning ladder: red: vertical support force, blue: horizontal support force, black: applied force

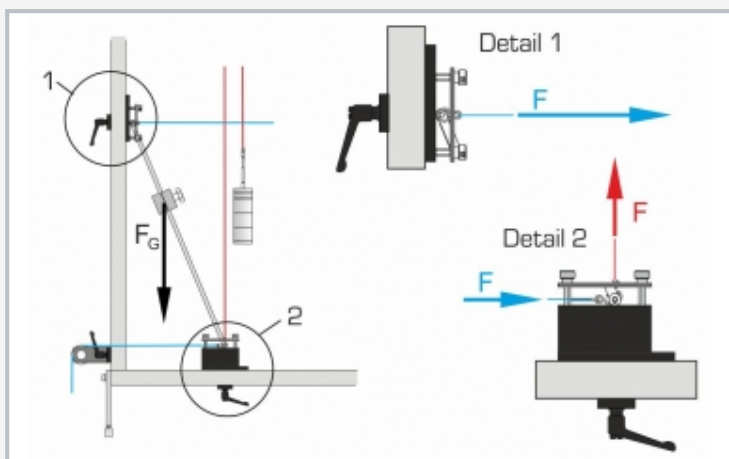

1 movable support, 2 fixed support;  $F_G$  applied force;  
red: cable with weights, compensates the vertical support force,  
blue: cable with weights, compensates the horizontal support force

### Specification

- [1] development of the static principle of "freeing"
- [2] full compensation of the support forces by cable forces
- [3] sliding clamp weight
- [4] determine the position of the clamp weight via steel rule with millimetre scale
- [5] 2 supports (1x fixed support, 1x movable support)
- [6] 3 guide pulleys
- [7] storage system for parts
- [8] experiment setup in the SE 112 mounting frame

### Technical data

#### Ladder

- length: 650mm
- weight: 2N
- built-in rule, graduation: 1 mm

Clamp weight: 20N

#### Weights

- 3x 1N (hanger)
- 9x 5N
- 12x 1N

#### Supports

- 2, clamped to mounting frame

#### Steel rule

- length: 1000mm, graduation: 1 mm

LxWxH: 1170x480x178mm (storage system)

Weight: approx. 28kg (total)

### Scope of delivery

- 1 model of a ladder
- 2 supports
- 3 guide pulleys
- 1 set of weights
- 1 clamp weight
- 3 cables
- 1 steel rule
- 1 storage system with foam inlay
- 1 set of instructional material

## **SE 110.53**

### **Equilibrium in a single plane, statically determinate system**

Required accessories

022.11200

SE 112

Mounting frame