

WP 960

Beam on two supports: shear force & bending moment diagrams



Description

- application of the method of sections to determine internal reactions of the beam
- direct indication of shear force and bending moment at a section on the beam

Statics observes the effect of forces on a rigid body, ignoring any possible deformations which may occur in the process. The forces are in equilibrium.

A simple example is a statically determinate bearing-mounted beam subjected to point loads. The reactions are determined from the conditions of equilibrium. To investigate the effect of the point loads in the beam, it is notionally split into two segments. Applying the method of sections, the internal forces and moments are plotted onto the two segments and calculated by way of conditions of equilibrium.

WP 960 includes a beam mounted on two supports. The beam is cut at one point. At that point there is a low-friction hinge with two degrees of freedom. Two force gauges determine the internal reactions to the externally applied forces at the section. The shear force is recorded and displayed directly by a force gauge.

The bending moment occurring at the section is recorded by a second force gauge acting on a fixed lever arm. This force readout, divided by $1Q$, gives the bending moment in Nm. Adjuster nuts on the two force gauges are used to align the beam horizontally and balance out any deflection.

In evaluating the experiment it becomes clear that the shear force, as opposed to the bending moment, is mostly negligible when designing components.

The various elements of the experiment are clearly laid-out and housed securely in a storage system. The complete experimental setup is arranged on a frame.

Learning objectives/experiments

- calculation of the reactions arising from the static conditions of equilibrium
- application of the method of sections to calculate the internal forces and moments
 - ▶ under a point load
 - ▶ under multiple point loads
- calculation of the shear force diagram
- calculation of the bending moment diagram
- comparison of calculated and measured values for shear force and bending moment

WP 960

Beam on two supports: shear force & bending moment diagrams

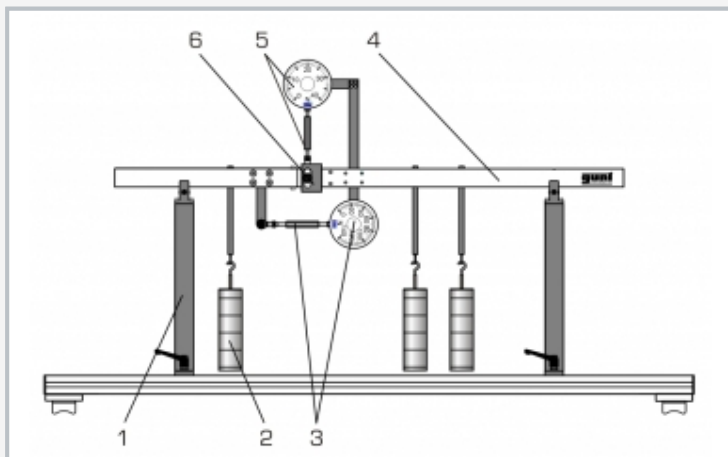

1 beam support, 2 weight, 3 force gauge with adjuster nut to determine the bending moment, 4 beam, 5 force gauge with adjuster nut (shear force), 6 hinge with 2 degrees of freedom

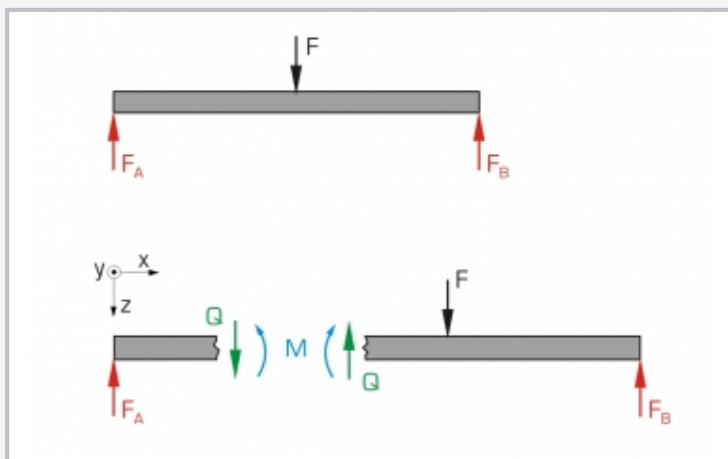

Internal forces on the beam under mid point load:
F applied point load, F_A/F_B reactions (Q,5F), Q shear force, M bending moment

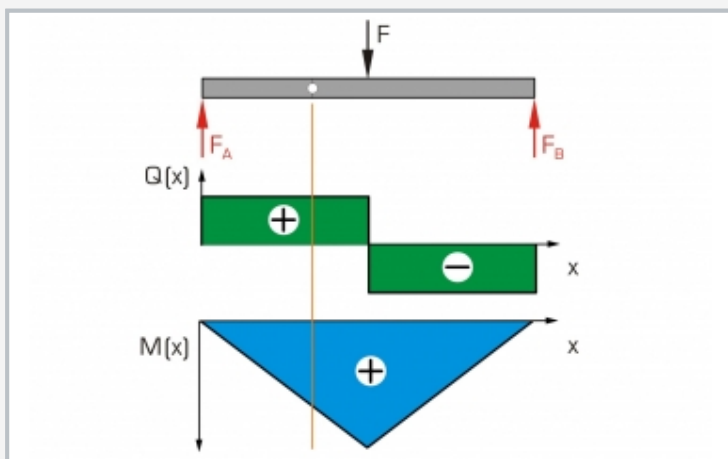

Shear force and bending moment diagram on beam with mid point load:
line (orange): position of the hinge at which the internal forces of the beam are indicated

Specification

- [1] determination of shear force and bending moment on beam mounted on 2 supports
- [2] measurement of shear force and bending moment in beam by low-friction hinge with 2 degrees of freedom
- [3] position of hinge at $1/3$ span
- [4] 2 bearing supports
- [5] loading of beam by 1 to 3 point loads
- [6] force gauges to indicate shear force and determine bending moment
- [7] bending moment determined by force measurement and lever arm
- [8] adjuster nuts for horizontal alignment of beam
- [9] steel rule to determine positions of point loads
- [10] storage system to house the components

Technical data

Beam

- total length: 1000mm
- span: 800mm

Weights

- 3x 1N (hanger)
- 12x 1N
- 9x 5N
- max. weight per hanger: 20N

Measuring ranges

- bending moment via force gauge and lever arm
 - ▶ lever arm: 100mm
 - ▶ force gauge: $\pm 100N$
 - ▶ bending moment: $\pm 10Nm$
- shear force: $\pm 50N$
- steel rule: 1000mm, graduation: 1mm

LxWxH: 1400x320x600mm

Weight: approx. 35kg

LxWxH: 1170x480x178mm (storage system)

Weight: approx. 12kg (storage system)

Scope of delivery

- 1 experimental unit
- 1 set of weights
- 1 set of accessories
- 1 storage system with foam inlay
- 1 set of instructional material

WP 960

Beam on two supports: shear force & bending moment diagrams

Optional accessories

020.30009

WP 300.09

Laboratory trolley